

Everbright Millennium Series Push-buttons



Everbright 2000 Series of EB-2000REL compact and LED illuminated push-button, take a firm stand against vandalism. They have been designed to enhance high class environments. With a large illuminated legend the push-buttons are easily visible from long distances.

The stainless steel plate of push-button are manufactured using Hair-line or Mirror 316 grade. Other customized stainless steel finishes are available on request.

The Technical Specification of push-buttons have self cleaning contacts in phosphorus bronze with platinum-plate, rated at 3A 220V a.c. or 0.5A 220V d.c. contacts configuration are either 2 N/O or 1 N/O + 1 N/C . Standard illumination is 12V or 24V d.c. The bodies have been molded in high grade polycarbonate and solid alloy surrounding with chromium-plate.

Approvals : Mechanical operation with electric load :	IEC60512-5
Impact testing :	BS5655 PT13
Corrosion resistant :	IEC60068-2-11 : 1981
Ingress protection :	IP41 . IEC60529 : 2001
Fire hazard test :	IEC60695-2-1/0 : 1994

The models are available in LED illuminated and Non-illuminated:

EB20-REL - LED illuminated with Hair-line 316 Stainless Steel Plate.

EB20-RNE - Non-illuminated with Hair-line 316 Stainless Steel Plate.

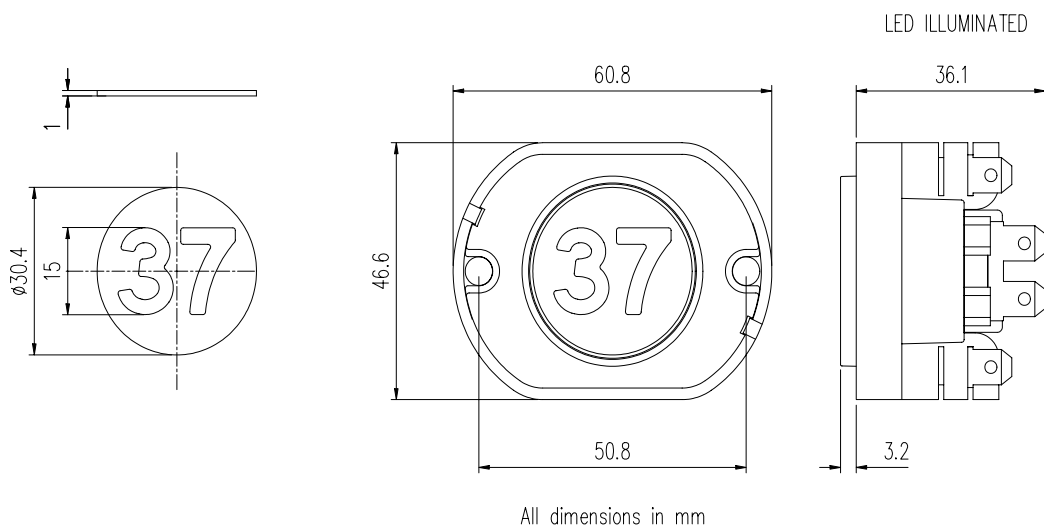

EB-2000REL Vandal-resistant Push-Button