

Everbright Micro Push-button Series



Everbright 2003 Series of micro push button are designed for use where either vandalism or heavy duty use is an absolute requirement. Designed for high class environment, the bright LED rim and clear floor illumination are easily visible form long distance.

The Pressel is manufactured from 316 or 304 stainless steel and is available as standard in a hairline finish, with options for mirror of gold. Floor legends are 12 or 15mm high.

Technical Specification:

<i>Weight :</i>	<i>55 grams</i>
<i>Construction:</i>	<i>Bodies moulded in high grade polycarbonate, with surround in solid alloy, chromium plated.</i>
<i>Pressel:</i>	<i>Standard hairline 316 stainless steel.</i>
<i>LED Voltage:</i>	<i>Single illumination 12/24/30V a.c./d.c.</i>
<i>LED colour:</i>	<i>Standard illumination in red.</i>
<i>LED current:</i>	<i>28mA</i>
<i>Contact arrangement:</i>	<i>1 N/O</i>
<i>Contact rating:</i>	<i>50mA 24V d.c. (resistive load)</i>
<i>Operation cycle:</i>	<i>1,000,000</i>

The models are available in LED illuminated :

EB03-REL - LED illuminated with Hair-line 316 Stainless Steel Plate.

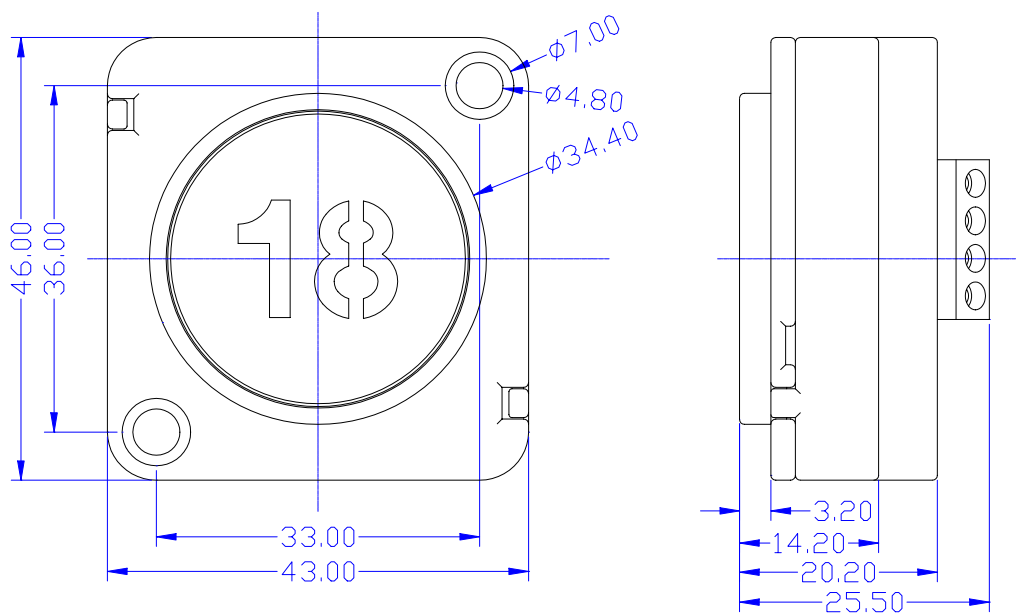

EB-2003REL Vandalism Push-Button